

LAY SHAFT INSPECTION REPORT

CUSTOMER _____ UNIT NO. _____
 ENGINE/COMPRESSOR MODEL _____
 ENGINE/COMPRESSOR MAKE _____

DATE _____
 SERIAL NO. _____
 SHOP ORDER# _____

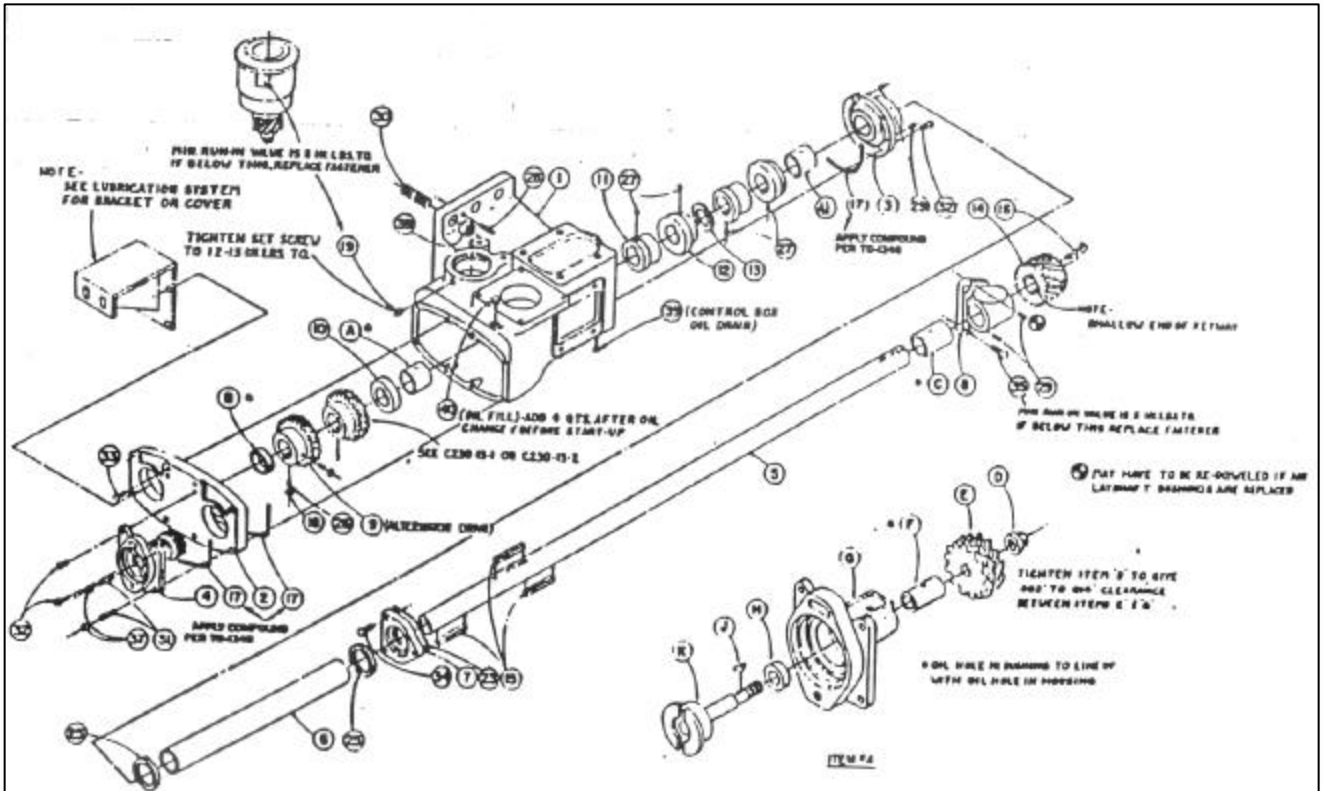

CONTROL BOX BUSHING (A)	OK	CLEARANCE _____	REPLACED
FRONT COVER BUSHING (A1)	OK	CLEARANCE _____	REPLACED
MAG DRIVE GEAR (E)	GOOD	REPLACED DUE TO : _____	
GOVERNOR DRIVE GEAR (9)	GOOD	REPLACED DUE TO : _____	
A/S LOBES (11)	GOOD	REPLACED DUE TO : _____	
HYD. LOBES (12)	GOOD	REPLACED DUE TO : _____	
MECH SEAL	REPLACED		
TUBE SEALS (25)	REPLACED		
GASKETS (23)	REPLACED		
CE BUSHING (B)	GOOD	SIZE _____	REPLACED DUE TO : _____
CE GEAR, DRIVE (14)	GOOD	SIZE _____	REPLACED DUE TO : _____
CE GEAR KEY (16)	GOOD	SIZE _____	REPLACED DUE TO : _____
SHAFT (5)	GOOD	SIZE _____	REPLACED DUE TO : _____

TECHNICIAN: _____
 APPROVED: _____