

PRODUCT BULLETIN

PB No. 118
Rev. 1

SUBJECT: New Lube Oil Header Design:
For Superior Inline Engines (**Upgrade**)

PROBLEMS: Existing fabricated Superior inline engines are equipped with copper & brass type lube oil headers. These headers are prone to develop leaks at the soldered joints, which creates downtime and costly repairs.

SOLUTIONS: In addition to our fabricated steel design (Ref. TB#111) EnDyn is pleased to announce an aluminum lube oil header design. This design is fully machined from a high grade aluminum alloy, complete with anodizing for protection from any corrosive environment. Additionally, upgraded viton o-rings (standard with our kit) provide superb sealing. A drawing of a typical header kit for an 8 & 6 cylinder engine is attached for review.

Successful field testing of this design as well as a competitive price, makes this upgrade kit a must.

For additional information, price, etc., please contact your **PowerParts[®]** Distributor or **EnDyn's** Sales Department.

8/22/07

MARKETING SERVICE DEPT.
300 West First
Alice, Texas 78332 USA
361.668.8311
800.723.6396
fax 361.668.3906
www.endyn.com

BILL OF MATERIALS			
ITEM	PART NUMBER	DISCRIPTION	QTY
1	P-012-378-1	UNION BLOCK	4
2	P-012-378-2	UNION BLOCK	2
3	P-012-378-3	UNION BLOCK	1
4	P-012-378-4	CONNECTION	2
5	P-012-378-5	CONNECTION	3
6	P-012-378-6	CONNECTION	1
7	P-012-378-7	CONNECTION (PIPE)	1
8	P-900-835-038-X	O-RING	24
9	P-034-958	GASKET	7
10	P-01CS0630-PC	CAPSCREW	14
11	P-01LW0600-PO	LOCK WASHER	14

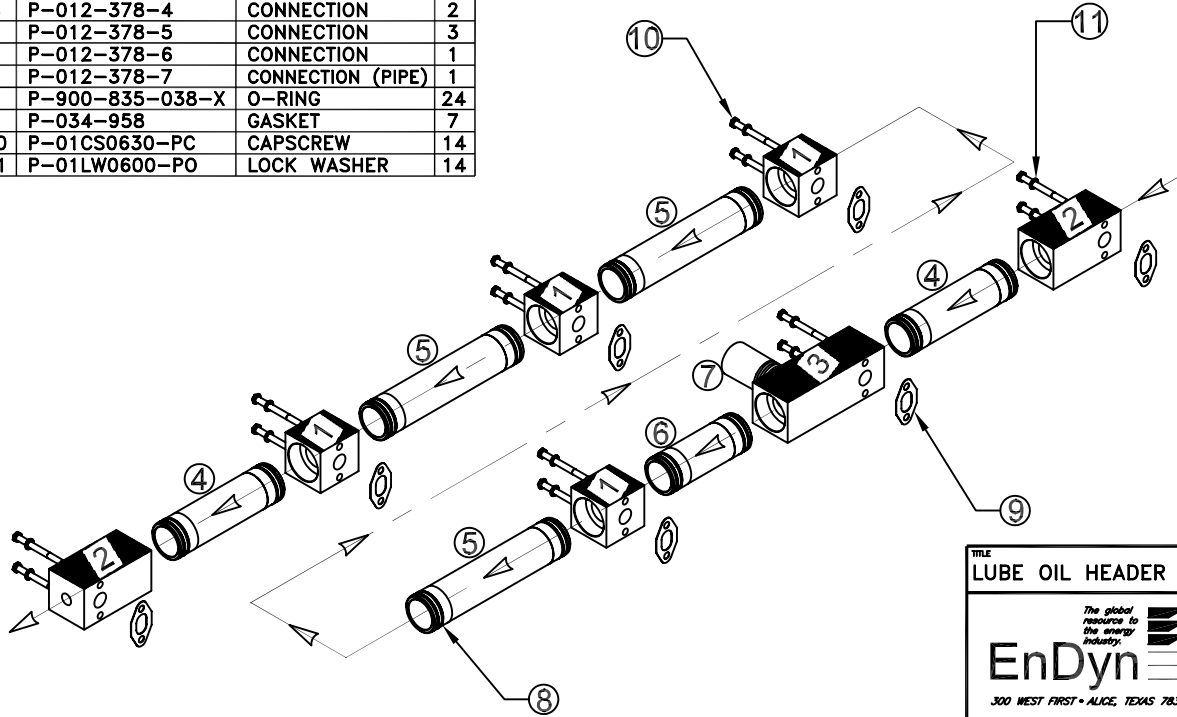

TITLE
LUBE OIL HEADER ASSY

The global resource to the energy industry.

EnDyn

300 WEST FIRST • ALICE, TEXAS 78332 USA

THIS PRINT IS PROVIDED ON A RESTRICTED BASIS. NOT TO BE USED IN ANY WAY DETRIMENTAL TO THE INTEREST OF ENDYN.

DRAWING NUMBER
P-012-378-SP-6

BILL OF MATERIALS			
ITEM	PART NUMBER	DISCRIPTION	QTY
1	P-012-378-1	UNION BLOCK	6
2	P-012-378-2	UNION BLOCK	2
3	P-012-378-3	UNION BLOCK	1
4	P-012-378-4	CONNECTION	2
5	P-012-378-5	CONNECTION	5
6	P-012-378-6	CONNECTION	1
7	P-012-378-7	CONNECTION (PIPE)	1
8	P-900-835-038-X	O-RING	32
9	P-034-958	GASKET	9
10	P-01CS0630-PC	CAPSCREW	18
11	P-01LW0600-PO	LOCK WASHER	18

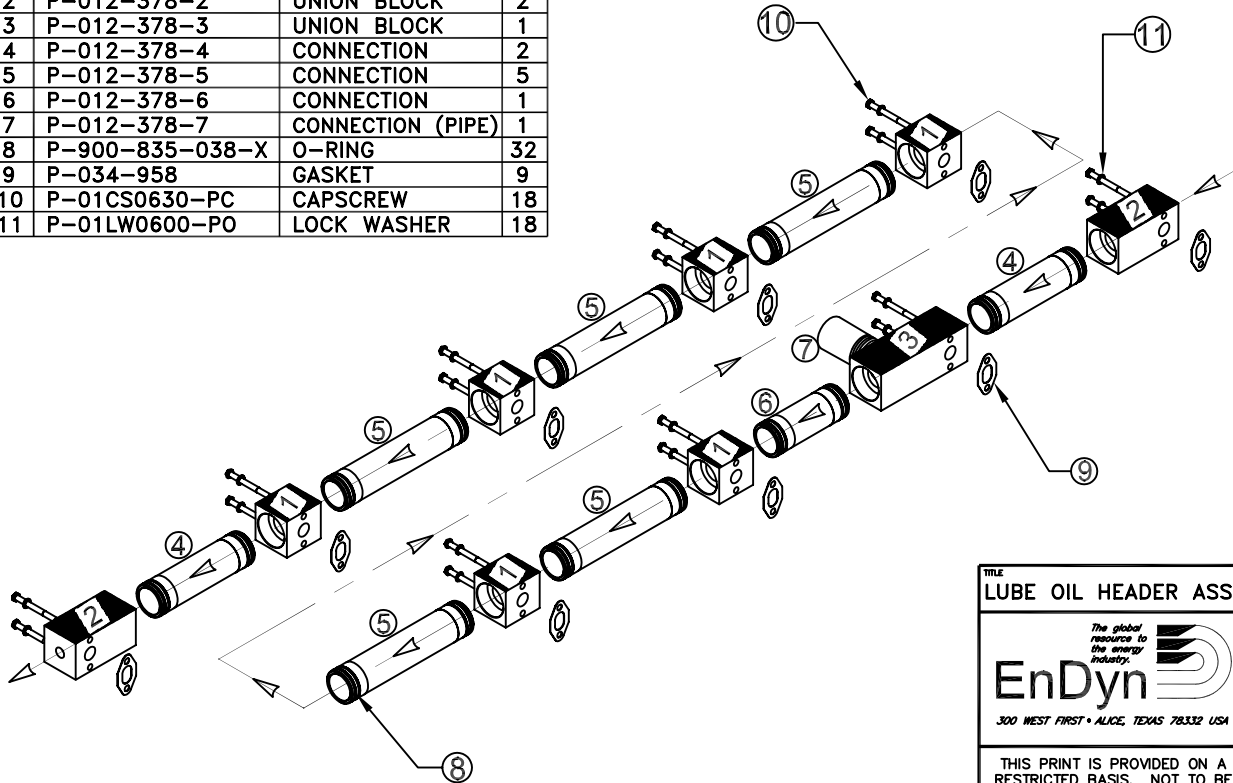

TITLE
LUBE OIL HEADER ASSY

The global resource to the energy industry.

EnDyn

300 WEST FIRST • ALICE, TEXAS 78332 USA

THIS PRINT IS PROVIDED ON A RESTRICTED BASIS. NOT TO BE USED IN ANY WAY DETRIMENTAL TO THE INTEREST OF ENDYN.

DRAWING NUMBER
P-012-378-SP-8