

## TECHNICAL BULLETIN

**TB NO.1014**  
**REV. 0**

**SUBJECT: DESIGN OF OIL PUMP GEARS**  
**SUPERIOR "VEE" ENGINES**  
**P-002-897**  
**P-YHST-13-B-4**

Our competitors have opted to discontinue the "herringbone" designed oil pump gears and to replace them with a "spur" or straight toothed gear design. When this change was made we began to receive calls from the field, with customers questioning the use of spur gears in their oil Pumps. Hence, we decided to look at the pros and cons of each design. Some of these are as follows:

1. The herringbone gears have no side thrust. The "Vee" shaped teeth wedge automatically into the mating gear, thus eliminating all axial motion. The constant axial drift between two spur gears can result in pitting and unnecessary wear at relatively low loads.
2. Due to the arch-like construction, the herringbone gear teeth are much stronger than the spur gear.
3. Herringbone gears have greater load carrying capacities than the spur gears due to the uniformity across the tooth face and the balanced thrusts of the opposing helices.
4. Herringbone gears run much more silent than spur gears.
5. Herringbone gears experience little impact stresses due to the avoidance of axial deflection.
6. Herringbone gears have superior self-lubricating characteristics due to the oil film formed by the "wedge action" of the teeth.

Obviously, herringbone gears are of a much more efficient and higher quality design. Due to these reasons, **EnDyn** has decided to continue providing herringbone gears for Superior "Vee" engine oil pumps.

For further information, pricing or availability of Superior Vee oil pump gears, please contact your local authorized **PowerParts**<sup>®</sup> Distributor or **EnDyn** direct.

1-12-93

**TECHNICAL SERVICE DEPT.**  
300 West First  
Alice, Texas 78332 USA  
361.668.8311  
800.723.6396  
fax 361.668.3906  
[www.endyn.com](http://www.endyn.com)

SPUR/STRAIGHT GEARS

HERRINGBONE GEARS

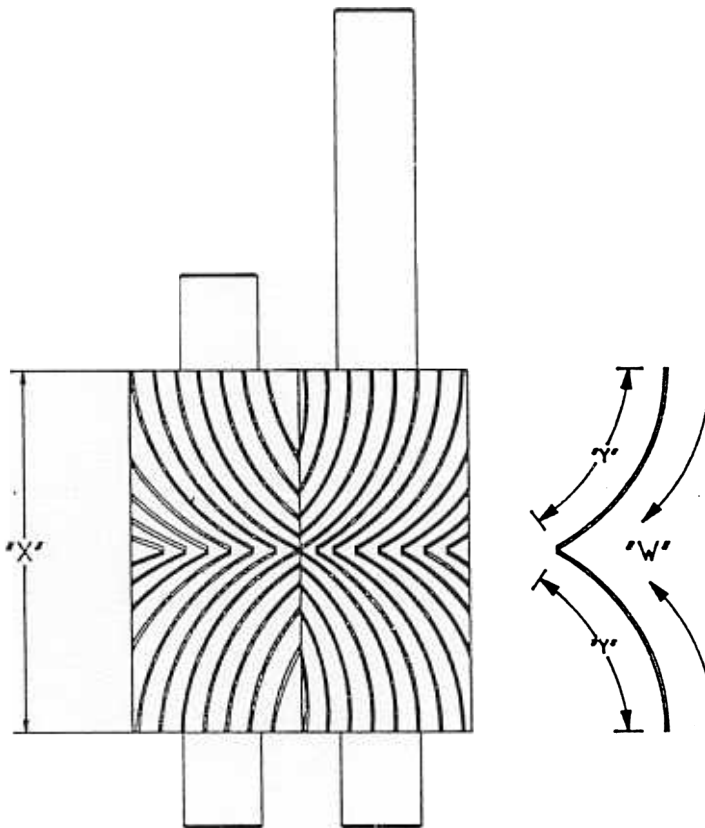
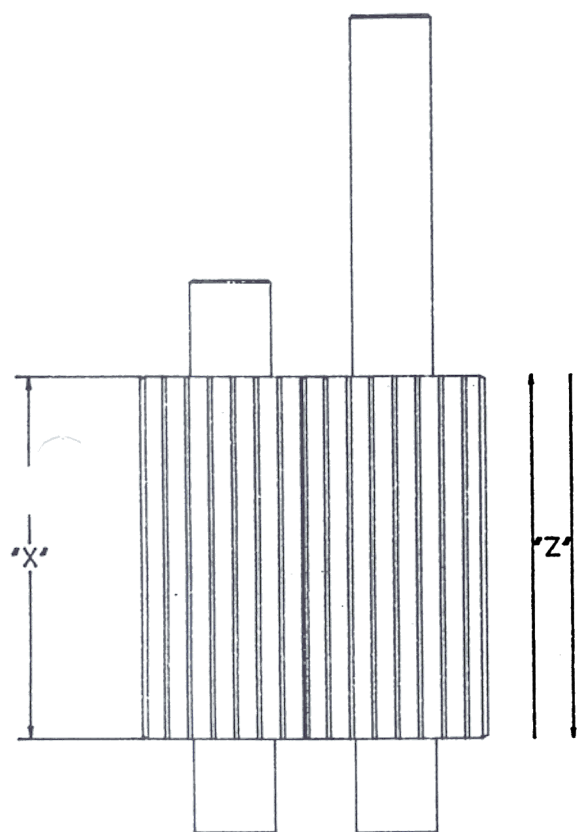

- A. THE SPUR GEARS HAVE ONE TOOTH PER GEAR CARRYING THE LOAD.
- B. 'X' IS EQUAL ON BOTH GEAR DESIGNS. THE 8" STRAIGHT GEARS HAVE 8" OF CONTACT SURFACE PER TOOTH.
- C. SPUR GEARS CAN HAVE A PARALLEL DRIFT BETWEEN THE DRIVE GEAR AND THE DRIVEN GEAR. (SEE 'Z')

- A. THE HERRINGBONE GEARS WILL HAVE TWO TO THREE TEETH EACH IN CONTACT AT ONCE.
- B. 'Y' ON HERRINGBONE DESIGN EQUALS APPROXIMATELY 4.75'.  $Y(2) = 9.50'$  OF CONTACT SURFACE PER TOOTH.
- C. HERRINGBONE GEARS WILL SELF-CENTER. (SEE 'W')